



GLASDON JUBILEE 240TM

INSTRUCTION MANUAL



IMPORTANT NOTE:
THE BIN MUST BE SITED ON LEVEL GROUND TO ENSURE CORRECT ALIGNMENT OF THE DOOR AND BODY.



We recommend that a risk assessment is undertaken to identify an appropriate location for your waste collection unit. In order to reduce risk, some organisations decide to place the unit(s) a minimum of 5 metres away from buildings.

Please also refer to the 'Manual Handling Operations Regulations 1992' during the handling of the product and materials used for installation. Glasdon recommends that a full Health and Safety analysis is carried out prior to installation.

GLASDON JUBILEE 240

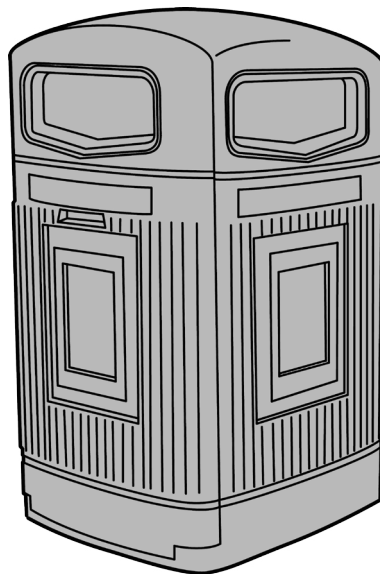

OPENING / CLOSING THE DOOR

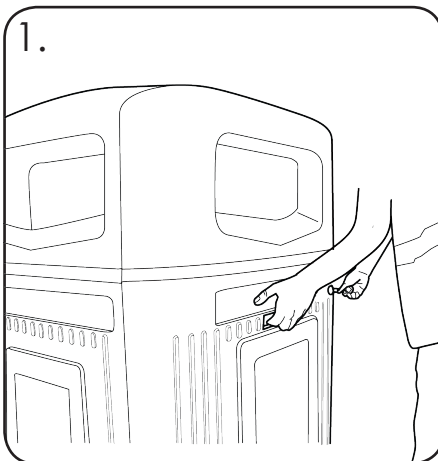

Insert the key into the key hole and place hand into the handle recess as shown.

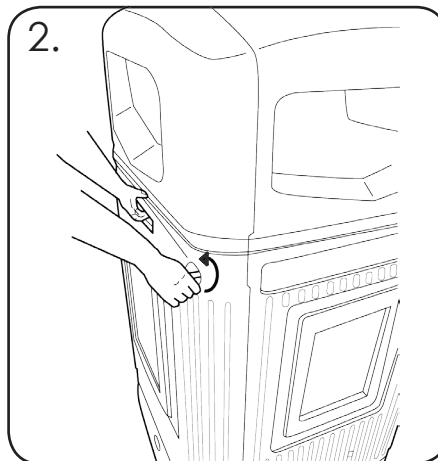

Turn the key anti-clockwise until it stops.

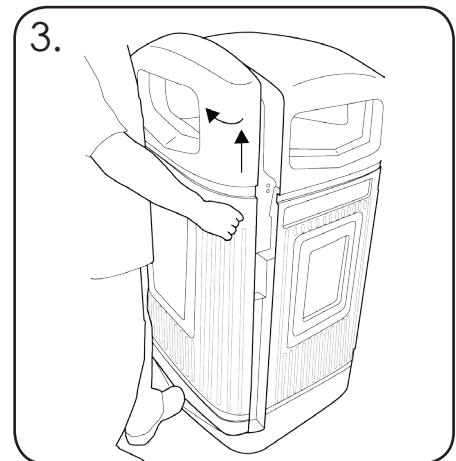

Using the handle lift the door and allow door to pivot open.

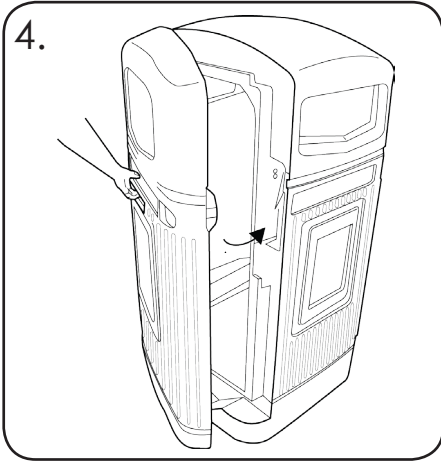

Slam to shut.

INSERTING THE WHEELED BIN (240L ONLY)



Open the lid of the wheeled bin.

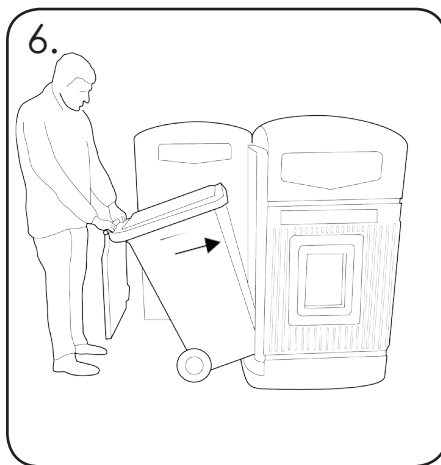

Push the wheelie bin into the housing so that the wheels sit in the location points within the base.

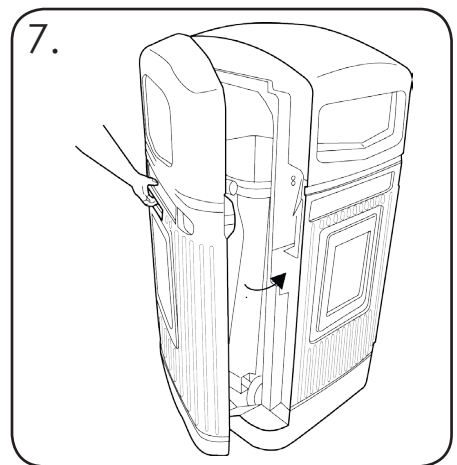

Slam door to shut.

INSERTING SACK INTO SACK RETENTION MODEL

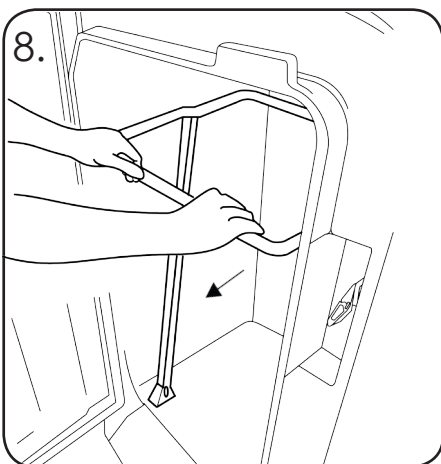

Present the Sack retention bands by pulling the bar towards the operator.

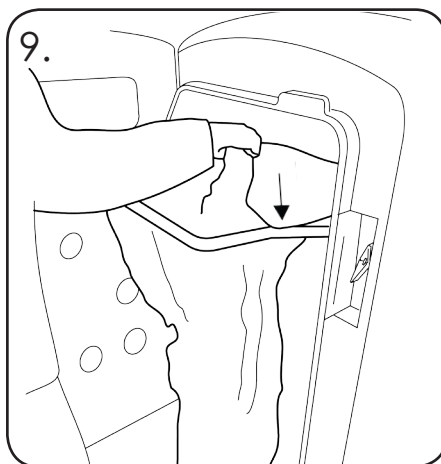

Lift up the sack retention and place the bag inside. Hook the bag over the sack retention bands. Push the sack band into the bin to secure the sack.

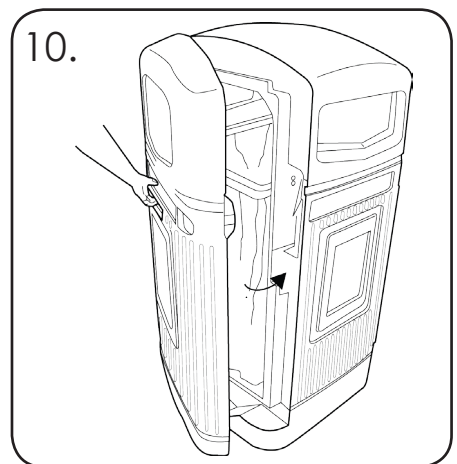

Place the sack retention into the bin and slam door to shut.

INSERTING / REMOVING THE POSTER (ACCEPTS LAMINATED A3 PAPER / CARD WITH A VISIBLE VIEWING AREA OF 297 x 405mm)

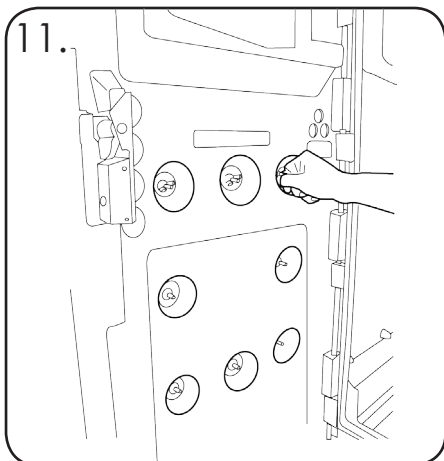

11. Remove all 8 wing nuts from door on the inside of the bin by unscrewing anti-clock wise.

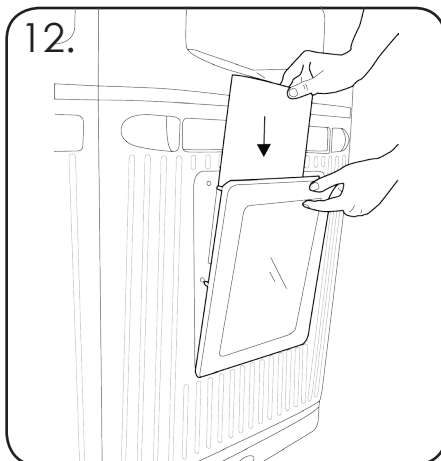

12. From the outside of the bin, remove the frame and insert/replace the poster behind the clear panel.

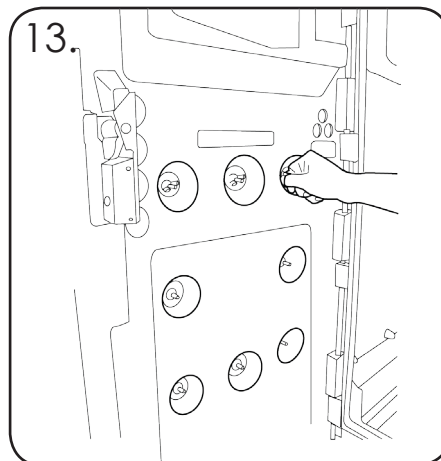

13. Place the frame back into position and tighten the wingnuts from the inside of the bin to secure.
IMPORTANT NOTICE: Do not over tighten wingnuts.

Cleaning Your Bin

We would recommend a warm pressure wash with soap or alternatively hand wash with 10% solution of mild detergent in warm water using a soft bristle brush followed by a rinse with clean water.

Graffiti

Felt tip pen or paint may be removed from Durapol using a proprietary graffiti remover. Carefully follow the instructions, particularly the guidelines covering safety. Ensure that all traces of chemicals are removed then clean as detailed above.

CAUTION:

Graffiti removers can damage stickers, some protection may be afforded by masking off such areas. Please refer to Technical Services for our recommended graffiti removal supplier.

Maintenance

A planned maintenance schedule of regular inspection is recommended and components replaced when necessary.

INSTRUCTIONS FOR CONCRETE FIXING KIT (INTO PREPARED CONCRETE FOUNDATION)

IMPORTANT NOTE: TO ENSURE A SECURE AND ROBUST INSTALLATION THE BIN SHOULD BE SITED ONTO A SOUND CONCRETE FOUNDATION AND THE 50MM DIAMETER WASHER MUST BE USED. WE STRONGLY RECOMMEND THAT THE BIN IS **NOT** INSTALLED ONTO TARMAC OR BLOCK PAVED AREAS.

DISTANCE FROM EDGE OF FOUNDATION TO CENTRE OF GROUND BOLT TO BE NO LESS THAN 110MM

Permanently sited onto a prepared concrete ground site (20-30N/mmsq) utilising 4 M10x120mm ground fixing bolts which are supplied with your bin.

- 1) Position bin onto siting area ensuring it is the correct distance away from the edge of the concrete (minimum 110mm) and is in the correct orientation with regard to the apertures.
- 2) From the inside of the bin mark hole positions onto the concrete through the fixing holes in the base of the bin with a 12mm diameter masonry drill. Remove the bin.
- 3) Using a 12mm diameter masonry drill bit, drill and clean out anchor holes to a minimum depth of 130mm. Position bin back over the drilled holes.
- 4) Assemble the ground bolts as shown in the diagram opposite by removing the 20mm washer and replacing it with the 50mm washer. Drive the ground bolts through the holes in the base of the bin and into the holes in the concrete.
- 5) Tighten nut with correct spanner until fixings are secure. Max recommended torque setting - 20lbs/ft (27Nm).
- 6) In the event of the bin being removed, simply remove the bolt to leave the site hazard free.

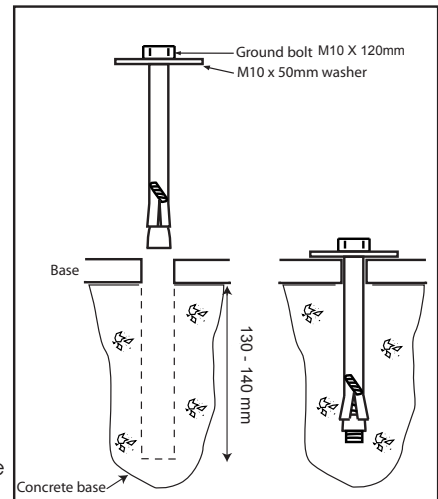

NOTE: For alternative fixing methods please contact us for details.

IMPORTANT NOTE: PLEASE ENSURE THAT ALL RELEVANT PERSONNEL READ THE POINTS LISTED WITHIN THIS LEAFLET AND THAT A COPY IS GIVEN TO STAFF INVOLVED WITH THE INSTALLATION AND MAINTENANCE OF THIS PRODUCT.

SAFETY NOTE: PLEASE REFER TO 'THE MANUAL HANDLING OPERATIONS REGULATIONS 1992' DURING HANDLING.

 **Glasdon** AND GLASDON JUBILEE ARE TRADEMARKS OR REGISTERED TRADEMARKS OF GLASDON GROUP OR ITS SUBSIDIARIES IN THE U.K. AND OTHER COUNTRIES

- A planned maintenance schedule or regular inspection is recommended, replacing components as necessary.
- Replacement components are available direct from GLASDON.
- GLASDON cannot be held responsible for claims arising from incorrect installation, unauthorised modifications or misuse of the product.

Issue 1 - April 2017 - Stock No. C000/0497 - DWG No. 07B-361-27

© Copyright APRIL 2017

Glasdon UK Ltd reserve the right to alter specifications without prior notice.

 **Glasdon**

Glasdon U.K. Limited

Preston New Road
BLACKPOOL
Lancashire FY4 4UL
Tel. : 01253 600410
Fax : 01253 792558
e-mail: sales@glasdon-uk.co.uk
web: www.glasdon.com